



GLOBAL LEADING PV MANUFACTURER

Henan Livefun Solar Technology Co.,Ltd. is a professional and fast growing company.The business covers the R&D, production and sales of PV modules.Power station and PV system products, power generation and operation and maintenance services,etc.The company is located in Zhengz City, Henan Province, which is one of the main production bases of the photovoltaic industry in the world.We are world-renowned manufacturer and supplier of solar cells, solar PV modules and solar systems.

Covering an area of 46000 square meters,we have more than 200 employees now,which makes annual production capacity of 800MW and 90% were exported all over the world. The advanced production system and excellent quality control have enabled us to win the trust and support of our customers.We have got certificates of TUV,CE,etc.At present, We has established a global sales network covering 70 countries/regions.Mainly covering Europe, Asia and South America, customers all over the world.

Livefun has a complete PV product system: solar cells, PV modules and PV systems, etc.The goal of PINERGY is to create a new first-class PV product brand, provide clean energy to the world, and assume future responsibility.

STAND THE TEST OF TIME

70+

GLOBAL BUSINESS FOOTPRINT

Chnlandd has it sales covered more than 70 countries around the world.

150+



GLOBAL PARTNERS

Chnland has more than 150 industry leading partners worldwide.

LEADING TECHNOLOGY

Livefun has standard and half-cell MBB production lines,supply high quality products.



-  Manufacturer bases
-  Business footprint
-  Headquarter

GLOBAL NETWORK

Livefun's business footprint covers more than 70 countries around the world, with more than 150 industry-leading partners.





FROM MANUFACTURING TO INTELLIGENT MANUFACTURING



AUTOMATIC MANUFACTURING

Livefun module factory can work for various advanced technology production requirements, and achieved the transition from manufacturing to intelligent manufacturing



1.AUTOMATIC CUTTING

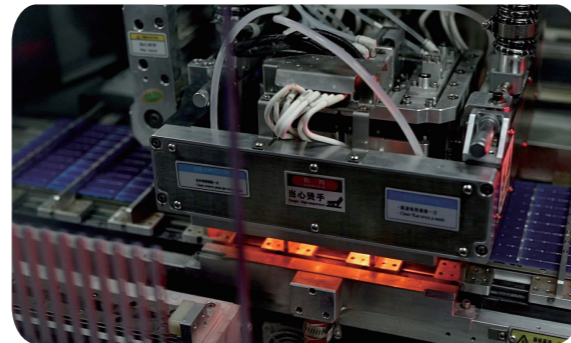

2.AUTOMATIC WELDING



3.AUTOMATIC SPLICING

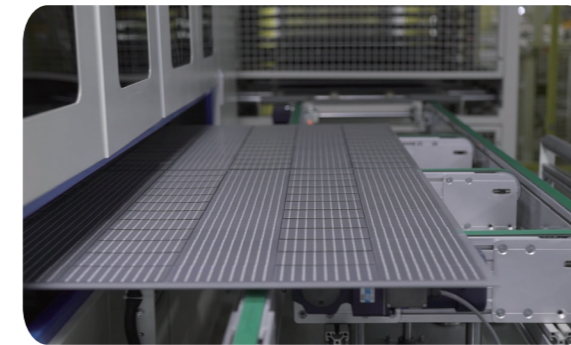

4.LAMINATED



5.EL TEST

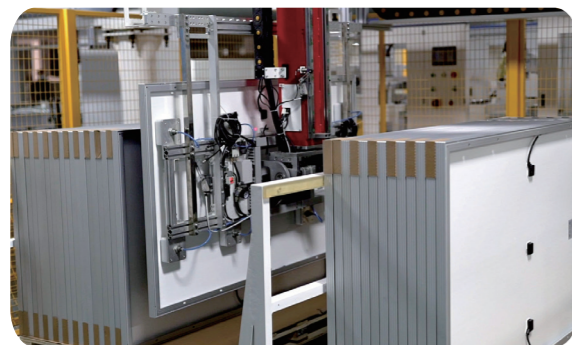

9.AUTOMATIC PACKING



8.VISUAL INSPECTION

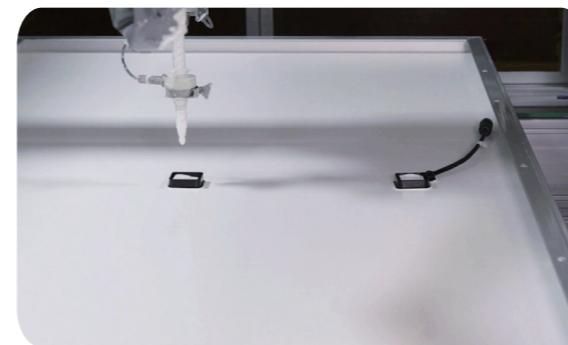

7.AUTOMATIC GLUE FILLING



6.AUTOMATIC FRAMING

TRUSTWORTHY QUALITY

GUARANTEED QUALITY

- 15 steps quality control and inspection process,2*100% EL test;
- 12 years quality guarantee,25 years power output warranty.

RIGOROUS CONTROL

- Stringent triple IEC test;
- FQC 100% appearance inspection,OBA appearance spot inspection,OQC delivery inspection.

MANAGEMENT SYSTEM

- Certification of ISO9001 quality system,ISO14001 environmental management system,OHASA18001 occupational health and safety management system.



LIVEFUN PRODUCTS

LIV60

Standard Series

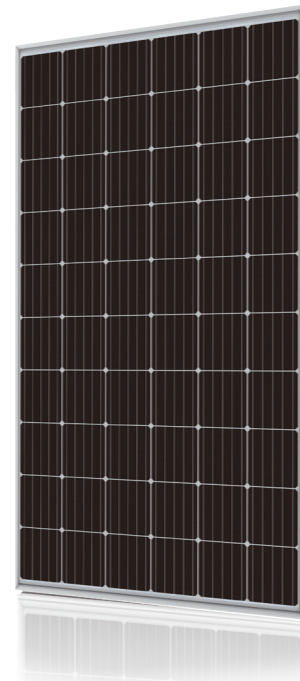
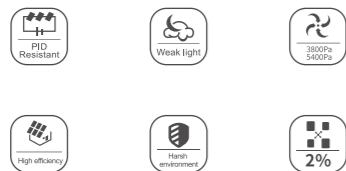

LIV144

Half Cell Series



LIV72

Standard Series

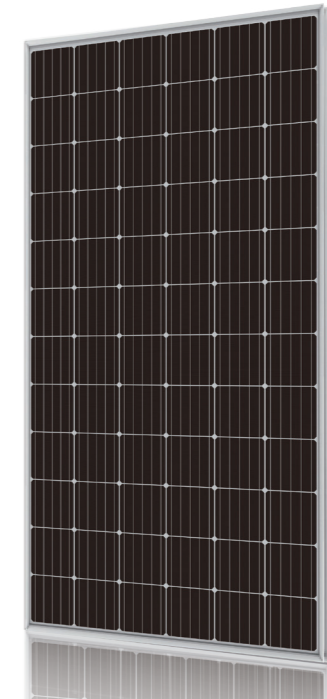

LIV120

Half Cell Series

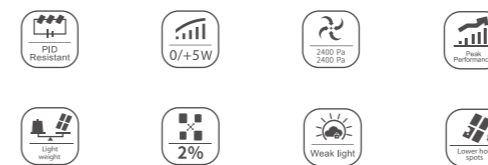

Excellent Manufacturing,Ultimate Pinergy.

5BB
POLY CRYSTALLINE MODULE
LIV-60P
270-285 Watt

Linear Performance Warranty

12 Years Product Warranty · 25 Years Linear Power Warranty

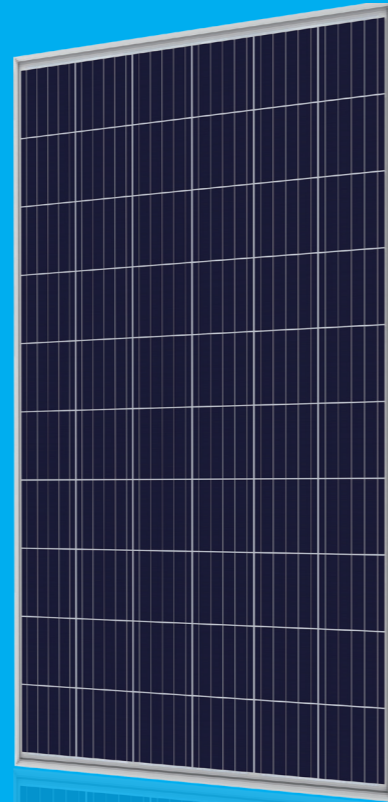
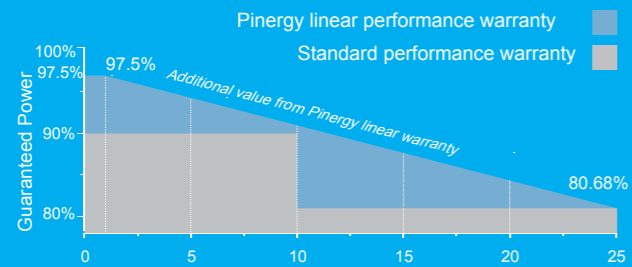

KEY FEATURES

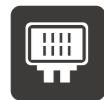

IP68 junction box, connector

IP68 junction box and connector have a high degree of waterproof, effectively resist the harsh environment;



15A current

The junction box carries a current of 15A, ensuring high current flow through the modules;



PID Resistant

Excellent PID resistance at 96 hours (85°C/85%) test,and also can be improved to meet higher standards for the particularly harsh environment;



Super strong frame

Glue-spilled tank has a double-layer waterproof, cross-section with hook-shaped aluminum frame, enhanced by 10% of the mechanical load strength;



Anti-Crack

Excellent anti-microcracking performance with more balanced interior stress;



Strong mechanical load capacity

Passed the 2400pa wind load and 5400pa snow load test, ensuring that the module has a stable mechanical life;

ELECTRICAL SPECIFICATIONS

Module Type	LIV 60P-270		LIV 60P-275		LIV 60P-280		LIV60P-285	
Testing Condition	STC	NOCT	STC	NOCT	STC	NOCT	STC	NOCT
Rated output (Pmp/Wp)	270	200.0	275	203.7	280	207.4	285	211.1
Short Circuit Current(Isc)	9.06A	7.33	9.18A	7.43	9.29A	7.52	9.38A	7.59
Open Circuit Voltage(Voc)	37.2V	34.4	38.0V	35.1	38.5V	35.6	38.7V	35.8
Maximum Power Current(Imp)	8.65A	6.89	8.76A	6.99	8.86A	7.07	8.96A	7.14
Maximum Power Voltage(Vmpp)	31.2V	29.0	31.4V	29.2	31.6V	29.3	31.8V	29.6
Module efficiency(%)	16.50%		16.80%		17.11%		17.41%	
Power Tolerance (W)	0~+5		0~+5		0~+5		0~+5	

Standard Test Condition (STC) : Irradiance 1000W/m², Cell Temperature 25°C, AM1.5

Nominal Module Operating Temperature (NMOT): Irradiance 800W/m², Ambient Temperature 20°C, AM1.5, Wind Speed 1m/s

TEMPERATURE CHARACTERISTICS

NOCT Temperature	45°C ±2°C
Temperature Coefficient (Pmax)	-0.41%/°C
Temperature Coefficient (Voc)	-0.33%/°C
Temperature Coefficient (Isc)	0.06%/°C

MECHANICAL SPECIFICATIONS

Cell Type	5BB POLY 156.75×156.75mm
No. of Cells	60 (6×10)
Dimension	1650×992×30mm
Weight	19kg
Glass	3.2mm, Low Iron Tempered Glass
Frame	Anodized Aluminium Alloy (silver or black)
Junction Box	IP68,with Bypass Diodes
Output Cables	TUV,±length 900mm,4.0mm²
Connector type	MC4 Compatible

PACKING CONFIGURATIONS

Container	20' GP	40' HQ
Pieces Per Pallet	35	35
Pallets Per Container	14	28
Pieces Per Container	460	1092

MAXIMUM RATINGS

Maximum system voltage (IEC)	1000V/1500V DC
Wind/Snow	5400Pa
Operating Temperature	-40°C ~ +85°C
Maximum series fuse rating	15A

Product And Quality Certifications

ISO 9001:2008 ISO 14001:2004 OHSAS 18001:2007



ENGINEERING DRAWINGS

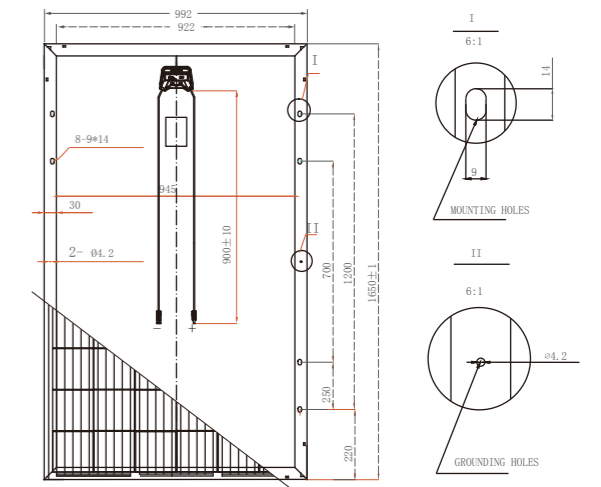

CURVE & TEMPERATURE DEPENDENCE

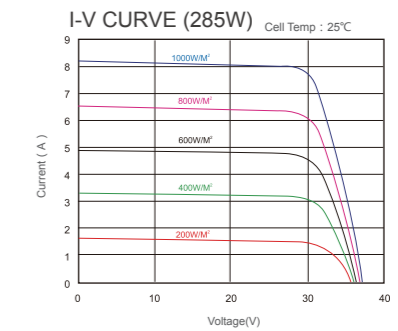

Power voltage current curve at different temperature

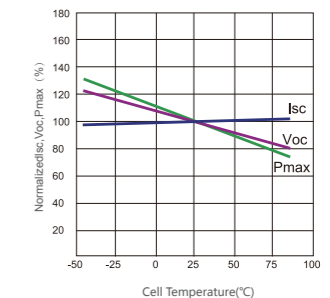

Excellent Manufacturing, Ultimate Pinergy.

5BB

PERC MONO CRYSTALLINE MODULE

LIV-60M

290-320 Watt

Linear Performance Warranty

12 Years Product Warranty · 25 Years Linear Power Warranty

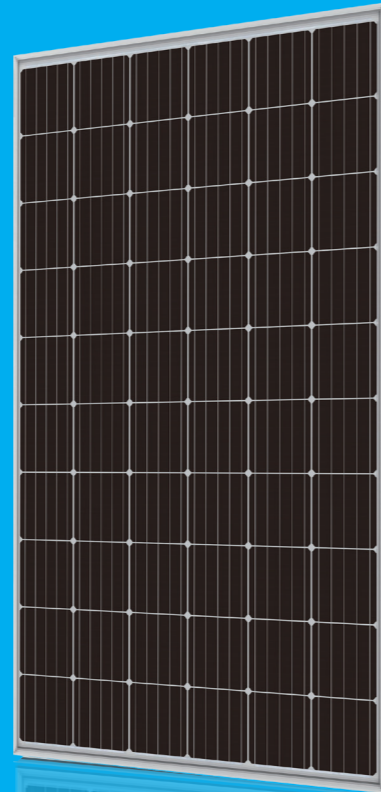
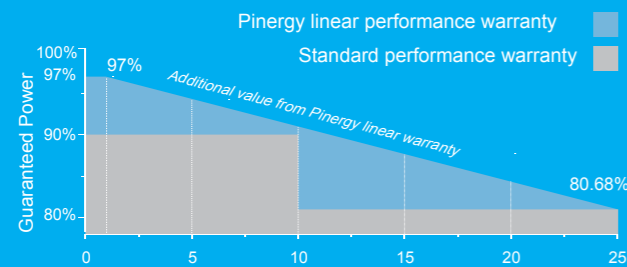

KEY FEATURES

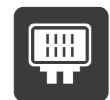

IP68 junction box, connector

IP68 junction box and connector have a high degree of waterproof, effectively resist the harsh environment;



15A current

The junction box carries a current of 15A, ensuring high current flow through the modules;



PID Resistant

Excellent PID resistance at 96 hours (85°C/85%) test, and also can be improved to meet higher standards for the particularly harsh environment;



Super strong frame

Glue-spilled tank has a double-layer waterproof, cross-section with hook-shaped aluminum frame, enhanced by 10% of the mechanical load strength;



Anti-Crack

Excellent anti-microcracking performance with more balanced interior stress;



Strong mechanical load capacity

Passed the 2400pa wind load and 5400pa snow load test, ensuring that the module has a stable mechanical life;

ELECTRICAL SPECIFICATIONS

Module Type	LIV60M-290		LIV60M-295		LIV60M-300		LIV60M-305		LIV60M-310		LIV60M-315		LIV60M-320	
	STC	NOCT	STC	NOCT	STC	NOCT	STC	NOCT	STC	NOCT	STC	NOCT	STC	NOCT
Rated output (Pmp/Wp)	290	216.2	295	219.9	300	223.6	305	227.4	310	231.1	315	235	320	239
Short Circuit Current(Isc)	9.58A	7.76	9.72A	7.87	9.78A	7.92	9.89A	8.01	9.96A	8.06	10.04A	8.33	10.15A	8.44
Open Circuit Voltage(Voc)	39.2V	36.2	39.6V	36.6	39.8V	36.8	40.1V	37.1	40.3V	37.3	40.7V	37.6	40.9V	37.8
Maximum Power Current(Imp)	8.95A	7.35	9.08A	7.46	9.17A	7.51	9.30A	7.59	9.40A	7.64	9.49A	7.69	9.59A	7.74
Maximum Power Voltage(Vmpp)	32.4V	29.4	32.5V	29.5	32.7V	29.8	32.8V	30.0	33.0V	30.2	33.2V	30.4	33.4V	30.6
Module efficiency(%)	17.72%		18.02%		18.33%		18.63%		18.94%		19.24%		19.55%	
Power Tolerance (W)	0~+5		0~+5		0~+5		0~+5		0~+5		0~+5		0~+5	

Standard Test Condition (STC) : Irradiance 1000W/m², Cell Temperature 25°C, AM1.5

Nominal Module Operating Temperature (NMOT): Irradiance 800W/m², Ambient Temperature 20°C, AM1.5, Wind Speed 1m/s

TEMPERATURE CHARACTERISTICS

NOCT Temperature	45°C ±2°C
Temperature Coefficient (Pmax)	-0.40%/°C
Temperature Coefficient (Voc)	-0.29%/°C
Temperature Coefficient (Isc)	0.05%/°C

MECHANICAL SPECIFICATIONS

Cell Type	5BB PERC MONO 156.75×156.75mm
No. of Cells	60 (6×10)
Dimension	1650×992×35mm
Weight	19kg
Glass	3.2mm, Low Iron Tempered Glass
Frame	Anodized Aluminium Alloy (silver or black)
Junction Box	IP68, with Bypass Diodes
Output Cables	TUV, ±length 900mm, 4.0mm ²
Connector type	MC4 Compatible

PACKING CONFIGURATIONS

Container	20' GP	40' HQ
Pieces Per Pallet	35	35
Pallets Per Container	14	28
Pieces Per Container	460	1092

MAXIMUM RATINGS

Maximum system voltage (IEC)	1000V/1500V DC
Wind/Snow	5400Pa
Operating Temperature	-40°C ~ +85°C
Maximum series fuse rating	15A

Product And Quality Certifications

ISO 9001:2008 ISO 14001:2004 OHSAS 18001:2007



ENGINEERING DRAWINGS

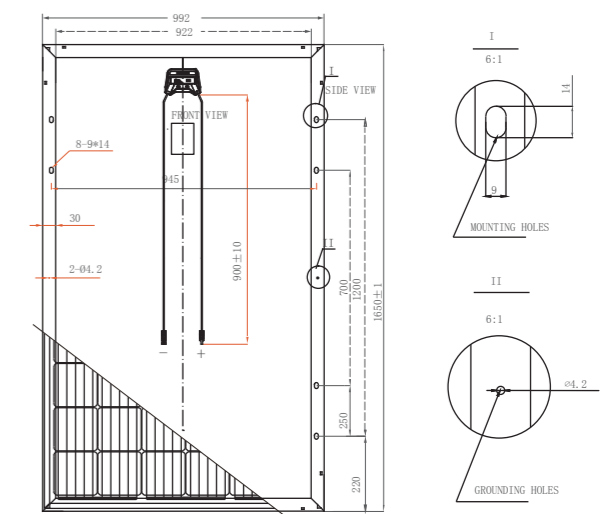

CURVE & TEMPERATURE DEPENDENCE

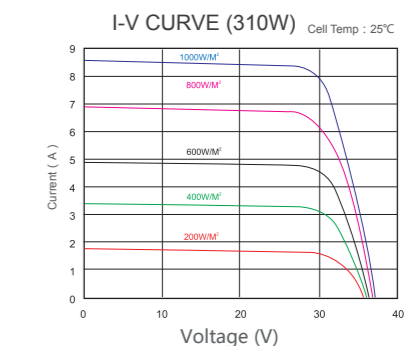

Power voltage current curve at different temperature

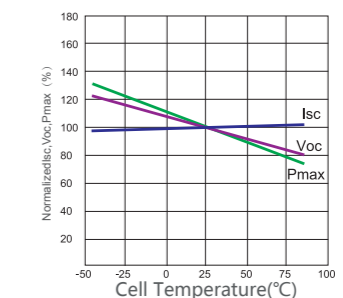

Excellent Manufacturing, Ultimate Pinergy.

5BB

POLY CRYSTALLINE MODULE

LIV-72P
320-340 Watt

Linear Performance Warranty

12 Years Product Warranty · 25 Years Linear Power Warranty

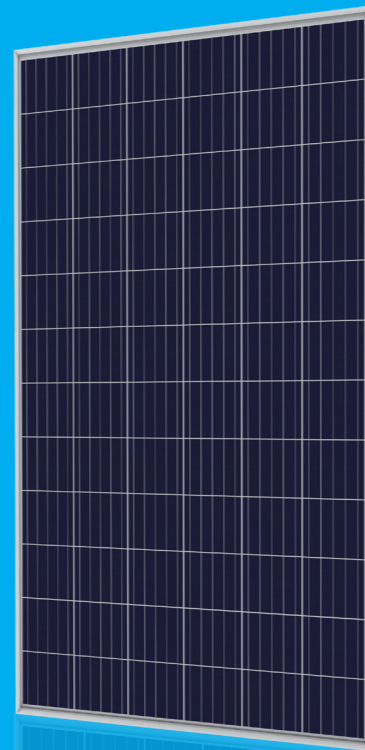
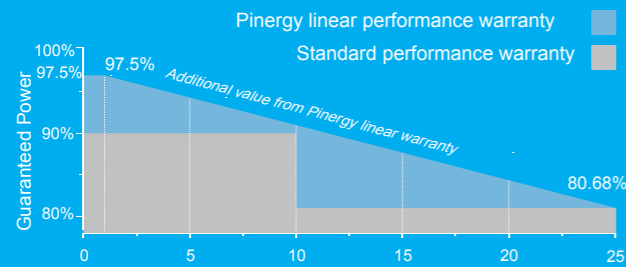

KEY FEATURES



IP68 junction box, connector

IP68 junction box and connector have a high degree of waterproof, effectively resist the harsh environment;



15A current

The junction box carries a current of 15A, ensuring high current flow through the modules;



PID Resistant

Excellent PID resistance at 96 hours (85°C/85%) test, and also can be improved to meet higher standards for the particularly harsh environment;



Super strong frame

Glue-spilled tank has a double-layer waterproof, cross-section with hook-shaped aluminum frame, enhanced by 10% of the mechanical load strength;



Anti-Crack

Excellent anti-microcracking performance with more balanced interior stress;



Strong mechanical load capacity

Passed the 2400pa wind load and 5400pa snow load test, ensuring that the module has a stable mechanical life;

ELECTRICAL SPECIFICATIONS

Module Type	LIV 72P-320		LIV 72P-325		LIV 72P-330		LIV 72P-335		LIV 72P-340	
Testing Condition	STC	NOCT	STC	NOCT	STC	NOCT	STC	NOCT	STC	NOCT
Rated output (Pmp/Wp)	320	237.1	325	240.8	330	244.5	335	248.2	340	251.9
Short Circuit Current(Isc)	9.03A	7.31	9.10A	7.37	9.22A	7.46	9.31A	7.54	9.37A	7.59
Open Circuit Voltage(Voc)	44.6V	41.2	44.9V	41.5	45.5V	42.1	46.1V	42.6	46.4V	42.9
Maximum Power Current(Imp)	8.53A	6.87	8.62A	6.92	8.73A	7.02	8.82A	7.08	8.90A	7.13
Maximum Power Voltage(Vmpp)	37.5V	34.5	37.7V	34.8	37.8V	34.8	38.0V	35.0	38.2V	35.3
Module efficiency(%)	16.50%		16.75%		17.01%		17.27%		17.52%	
Power Tolerance (W)	0~+5		0~+5		0~+5		0~+5		0~+5	

Standard Test Condition (STC) : Irradiance 1000W/m², Cell Temperature 25°C, AM1.5

Nominal Module Operating Temperature (NMOT): Irradiance 800W/m², Ambient Temperature 20°C, AM1.5, Wind Speed 1m/s

TEMPERATURE CHARACTERISTICS

NOCT Temperature	45°C ±2°C
Temperature Coefficient (Pmax)	-0.41%/°C
Temperature Coefficient (Voc)	-0.33%/°C
Temperature Coefficient (Isc)	0.06%/°C

MECHANICAL SPECIFICATIONS

Cell Type	5BB POLY 156.75×156.75mm
No. of Cells	72 (6×12)
Dimension	1956×992×35mm
Weight	23kg
Glass	3.2mm, Low Iron Tempered Glass
Frame	Anodized Aluminium Alloy (silver or black)
Junction Box	IP68, with Bypass Diodes
Output Cables	TUV, ±length 900mm, 4.0mm ²
Connector type	MC4 Compatible

PACKING CONFIGURATIONS

Container	20' GP	40' HQ
Pieces Per Pallet	30	30
Pallets Per Container	10	24
Pieces Per Container	300	804

MAXIMUM RATINGS

Maximum System Voltage	1000V/1500V DC
Maximum Series Fuse	15A
Increased Snowload Acc.to Iec 61215	5400Pa
Operating Temperature	-40~+85°C
Number Of Bypass Diodes	3

Product And Quality Certifications

ISO 9001:2008 ISO 14001:2004 OHSAS 18001:2007



ENGINEERING DRAWINGS

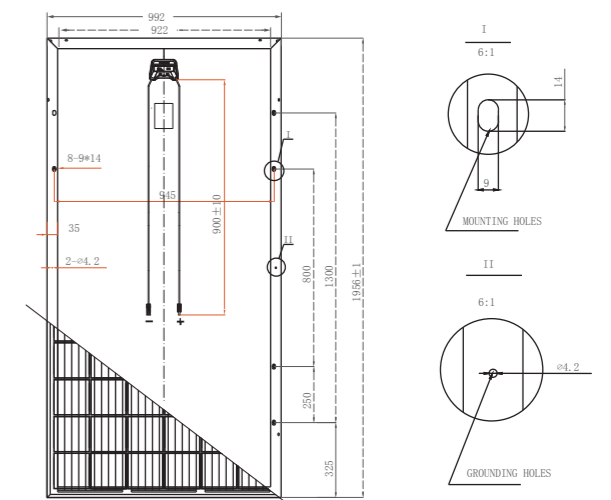

CURVE & TEMPERATURE DEPENDENCE

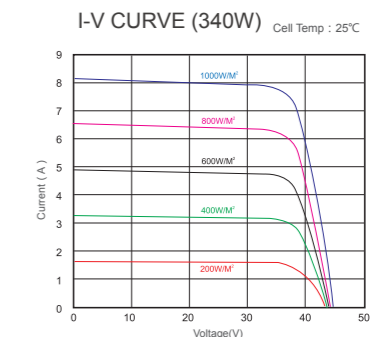

Power voltage current curve at different temperature

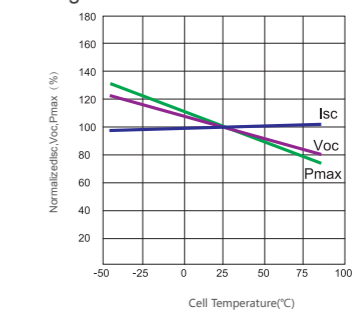

Excellent Manufacturing, Ultimate Pinergy.

5 BB

MONO CRYSTALLINE MODULE

LIV-72M

365-380 Watt

Linear Performance Warranty

12 Years Product Warranty · 25 Years Linear Power Warranty

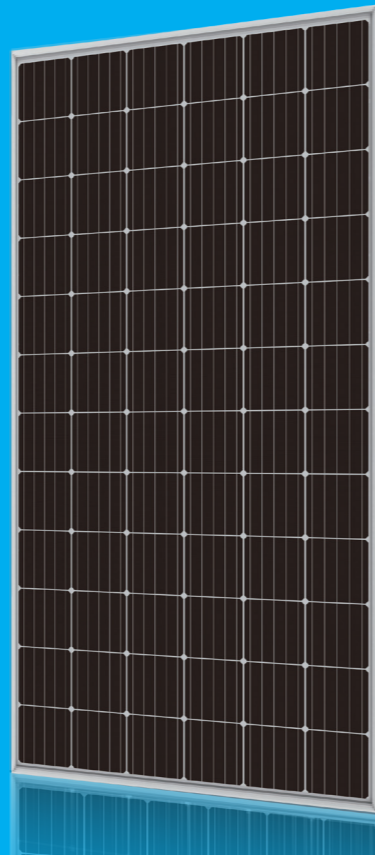
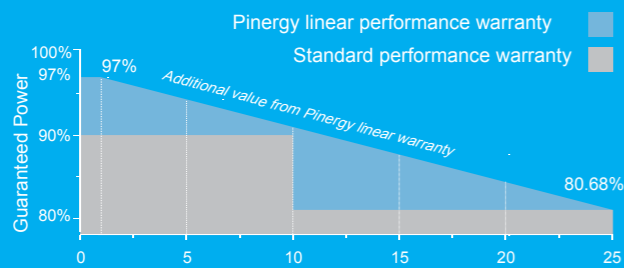

KEY FEATURES



IP68 junction box, connector

IP68 junction box and connector have a high degree of waterproof, effectively resist the harsh environment;



15A current

The junction box carries a current of 15A, ensuring high current flow through the modules;



PID Resistant

Excellent PID resistance at 96 hours (85 C/85%) test, and also can be improved to meet higher standards for the particularly harsh environment;



Super strong frame

Glue-spilled tank has a double-layer waterproof, cross-section with hook-shaped aluminum frame, enhanced by 10% of the mechanical load strength;



Anti-Crack

Excellent anti-microcracking performance with more balanced interior stress;



Strong mechanical load capacity

Passed the 2400pa wind load and 5400pa snow load test, ensuring that the module has a stable mechanical life;

ELECTRICAL SPECIFICATIONS

Module Type	LIV 72M-365		LIV 72M-370		LIV 72M-375		LIV 72M-380	
Testing Condition	STC	NOCT	STC	NOCT	STC	NOCT	STC	NOCT
Rated output (Pmp/Wp)	365	272.1	370	275.8	375	279.5	380	283.3
Short Circuit Current(Isc)	9.82A	7.95	9.85A	7.97	9.89A	8.01	9.97A	8.07
Open Circuit Voltage(Voc)	48.1V	44.5	48.3V	44.7	48.5V	44.8	48.7V	45.0
Maximum Power Current(Imp)	9.34A	7.54	9.41A	7.56	9.45A	7.59	9.52A	7.65
Maximum Power Voltage(Vmpp)	39.1V	36.1	39.3V	36.5	39.7V	36.8	39.9V	37.0
Module efficiency(%)	18.81%		19.07%		19.33%		19.58%	
Power Tolerance (W)	0~+5		0~+5		0~+5		0~+5	

Standard Test Condition (STC) : Irradiance 1000W/m², Cell Temperature 25 C, AM1.5

Nominal Module Operating Temperature (NMOT): Irradiance 800W/m², Ambient Temperature 20 C, AM1.5, Wind Speed 1m/s

TEMPERATURE CHARACTERISTICS

NOCT Temperature	45 C ±2 C
Temperature Coefficient (Pmax)	-0.40%/ C
Temperature Coefficient (Voc)	-0.29%/ C
Temperature Coefficient (Isc)	0.05%/ C

MECHANICAL SPECIFICATIONS

Cell Type	5BB MONO 156.75×156.75mm
No. of Cells	72 (6×12)
Dimension	1956×992×35mm
Weight	23kg
Glass	3.2mm, Low Iron Tempered Glass
Frame	Anodized Aluminium Alloy (silver or black)
Junction Box	IP68, with Bypass Diodes
Output Cables	TUV, ±length 900mm, 4.0mm ²
Connector type	MC4 Compatible

PACKING CONFIGURATIONS

Container	20' GP	40' HQ
Pieces Per Pallet	30	30
Pallets Per Container	10	24
Pieces Per Container	300	804

MAXIMUM RATINGS

Maximum system voltage (IEC)	1000V/1500V DC
Wind/Snow	5400Pa
Operating Temperature	-40 C ~ +85 C
Number Of Bypass Diodes	3

Product And Quality Certifications

ISO 9001:2008 ISO 14001:2004 OHSAS 18001:2007



ENGINEERING DRAWINGS

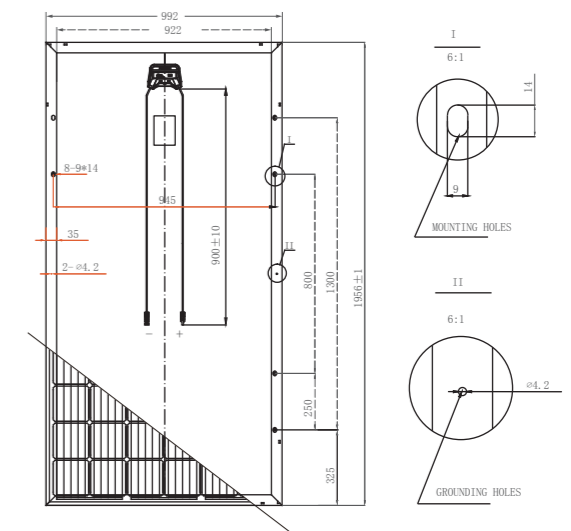

CURVE & TEMPERATURE DEPENDENCE

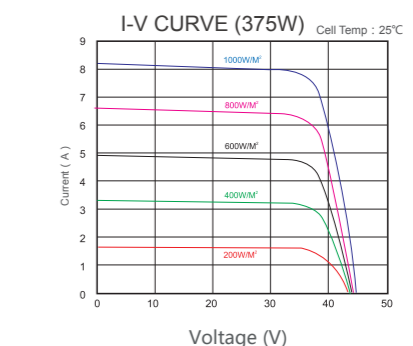

Power voltage current curve at different temperature

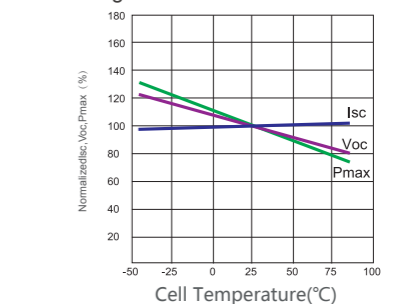

Excellent Manufacturing, Ultimate Pinergy.

5BB

MONO CRYSTALLINE MODULE

LIV-72M-F

380-400 Watt

Linear Performance Warranty

12 Years Product Warranty · 25 Years Linear Power Warranty

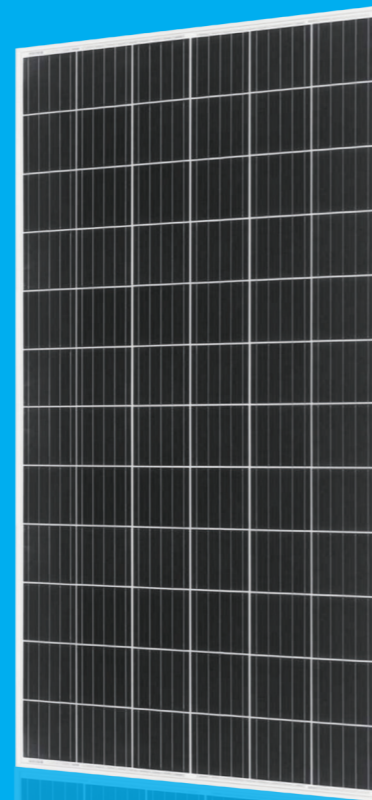
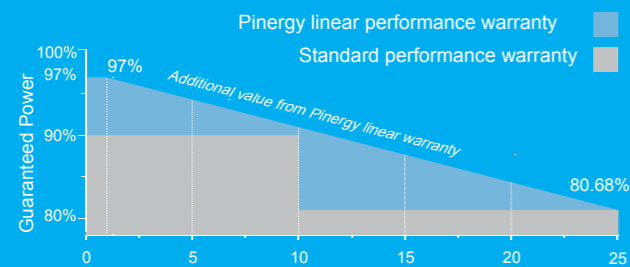

KEY FEATURES

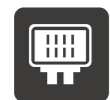

IP68 junction box, connector

IP68 junction box and connector have a high degree of waterproof, effectively resist the harsh environment;



15A current

The junction box carries a current of 15A, ensuring high current flow through the modules;



PID Resistant

Excellent PID resistance at 96 hours (85°C/85%) test, and also can be improved to meet higher standards for the particularly harsh environment;



Super strong frame

Glue-spilled tank has a double-layer waterproof, cross-section with hook-shaped aluminum frame, enhanced by 10% of the mechanical load strength;



Anti-Crack

Excellent anti-microcracking performance with more balanced interior stress;



Strong mechanical load capacity

Passed the 2400pa wind load and 5400pa snow load test, ensuring that the module has a stable mechanical life;

ELECTRICAL SPECIFICATIONS

Module Type	LIV 72M-F-380		LIV 72M-F-385		LIV 72M-F-390		LIV 72M-F-395		LIV 72M-F-400	
	STC	NOCT	STC	NOCT	STC	NOCT	STC	NOCT	STC	NOCT
Testing Condition	STC	NOCT	STC	NOCT	STC	NOCT	STC	NOCT	STC	NOCT
Rated output (Pmp/Wp)	380	283.3	385	287.0	390	290.7	395	294.4	400	300.7
Short Circuit Current(Isc)	9.97A	8.07	10.08A	8.16	10.14A	8.21	10.24A	8.29	10.31A	8.35
Open Circuit Voltage(Voc)	48.7V	45.0	48.9V	45.2	49.2V	45.5	49.4V	45.7	49.7V	46.3
Maximum Power Current(Imp)	9.52A	7.65	9.60A	7.74	9.68A	7.78	9.78A	7.86	9.85A	7.91
Maximum Power Voltage(Vmpp)	39.9V	37.0	40.1V	37.1	40.3V	37.4	40.4V	37.5	40.6V	38.0
Module efficiency(%)	19.16%		19.42%		19.67%		19.92%		20.17%	
Power Tolerance (W)	0~+5		0~+5		0~+5		0~+5		0~+5	

Standard Test Condition (STC) : Irradiance 1000W/m², Cell Temperature 25°C, AM1.5

Nominal Module Operating Temperature (NMOT): Irradiance 800W/m², Ambient Temperature 20°C, AM1.5, Wind Speed 1m/s

TEMPERATURE CHARACTERISTICS

NOCT Temperature	45°C ±2°C
Temperature Coefficient (Pmax)	-0.40%/°C
Temperature Coefficient (Voc)	-0.29%/°C
Temperature Coefficient (Isc)	0.05%/°C

MECHANICAL SPECIFICATIONS

Cell Type	MONO 158.75×158.75mm
No. of Cells	72 (6×12)
Dimension	1979×1002×35mm
Weight	23.2kg
Glass	3.2mm, Low Iron Tempered Glass
Frame	Anodized Aluminium Alloy (silver or black)
Junction Box	IP68, with Bypass Diodes
Output Cables	TUV, ±length 900mm, 4.0mm ²
Connector type	MC4 Compatible

PACKING CONFIGURATIONS

Container	20' GP	40' HQ
Pieces Per Pallet	27	27
Pallets Per Container	10	22
Pieces Per Container	300	704

MAXIMUM RATINGS

Maximum system voltage (IEC)	1000V/1500V DC
Wind/Snow	5400Pa
Operating Temperature	-40°C ~ +85°C
Number Of Bypass Diodes	3

Product And Quality Certifications

ISO 9001:2008 ISO 14001:2004 OHSAS 18001:2007



ENGINEERING DRAWINGS

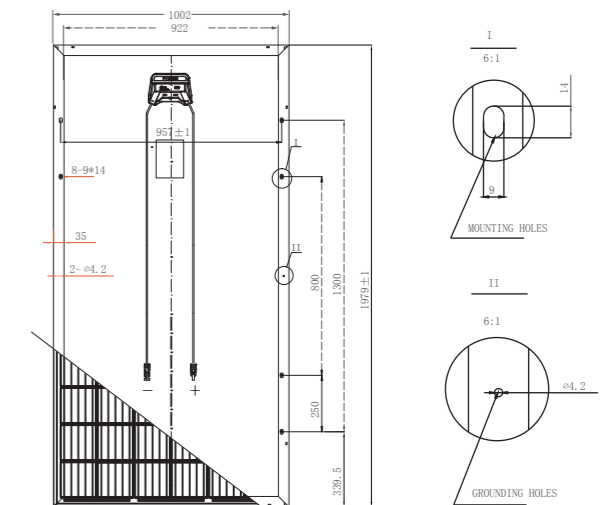

CURVE & TEMPERATURE DEPENDENCE

I-V CURVE (400W) Cell Temp : 25°C

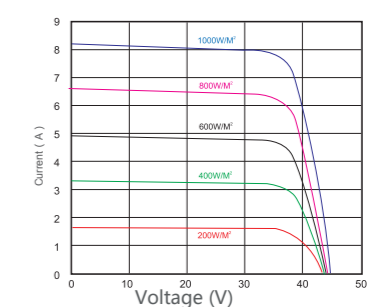

Power voltage current curve at different temperature

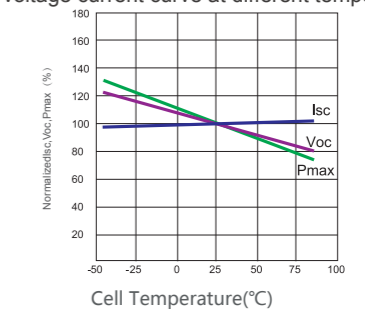

Excellent Manufacturing, Ultimate Pinergy.

9BB

Half-Cell MBB MONO MODULE

LIV-120M

320-345 Watt

Linear Performance Warranty

12 Years Product Warranty · 25 Years Linear Power Warranty

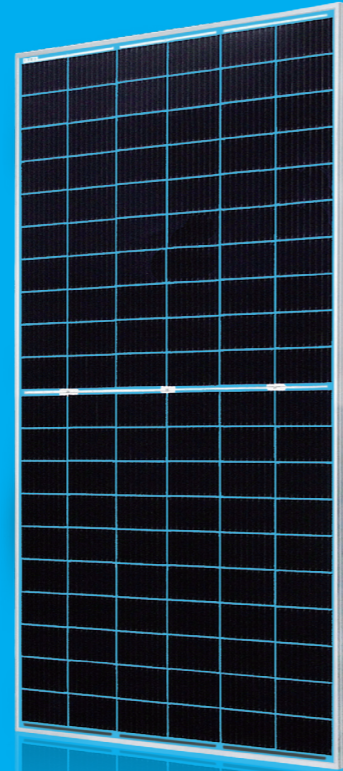
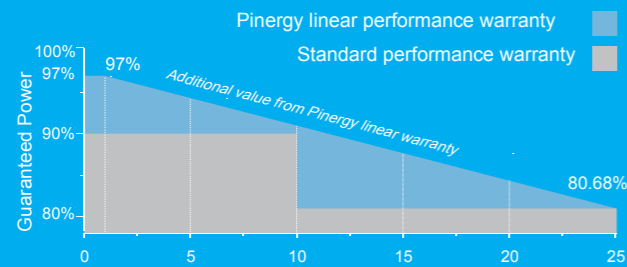

KEY FEATURES



Multi Busbar Solar Cell

Stronger current collection ability, Special circuit design with much lower hot spot temperature;



Module efficiency up to 20.45%

Half cell structure brings low resistance characteristic, higher lifetime generating capacity, simultaneously lower annual power attenuation;



PID Resistant

Excellent PID resistance at 96 hours (85 C /85%) test, and also can be improved to meet higher standards for the particularly harsh environment;



Low-Light Performance

Excellent power generation performance under Low-Light condition due to multi busbar; better shading response benefit from half cell module;



Anti-Crack

Excellent anti-microcracking performance with more balanced interior stress;



Strength and Durability

Certified for 5400Pa snow and 2400Pa loads test;

ELECTRICAL SPECIFICATIONS

Module Type	LIV120M-320		LIV120M-325		LIV120M-330		LIV120M-335		LIV120M-340	
	STC	NOCT	STC	NOCT	STC	NOCT	STC	NOCT	STC	NOCT
Testing Condition	STC	NOCT	STC	NOCT	STC	NOCT	STC	NOCT	STC	NOCT
Rated output (Pmp/Wp)	320	238.55	325	242.58	330	245.85	335	249.92	340	253.23
Rated voltage (Vmp/V)	33.06	30.90	33.44	31.30	33.80	31.60	34.16	32.00	34.52	32.30
Rated current (Imp/A)	9.68	7.72	9.72	7.75	9.76	7.78	9.81	7.81	9.85	7.84
Open circuit voltage (Voc/V)	39.85	37.10	40.15	37.30	40.44	37.60	40.71	37.80	40.98	38.10
Short circuit current (Isc/A)	10.12	8.19	10.16	8.22	10.20	8.25	10.24	8.28	10.28	8.31
Module efficiency(%)	18.96%		19.26%		19.56%		19.85%		20.15%	
Power Tolerance (W)	0~+5		0~+5		0~+5		0~+5		0~+5	

Standard Test Condition (STC) : Irradiance 1000W/m², Cell Temperature 25 C, AM1.5

Nominal Module Operating Temperature (NMOT): Irradiance 800W/m², Ambient Temperature 20 C, AM1.5, Wind Speed 1m/s

TEMPERATURE CHARACTERISTICS

NOCT Temperature	44 C ±2 C
Temperature Coefficient (Pmax)	-0.38%/ C
Temperature Coefficient (Voc)	-0.30%/ C
Temperature Coefficient (Isc)	0.06%/ C

MECHANICAL SPECIFICATIONS

Cell Type	9BB MONO 158.75×79.375mm
No. of Cells	120 (6×20)
Dimension	1684×1002×35mm
Weight	19.5kg
Glass	3.2mm, Low Iron Tempered Glass
Frame	Anodized Aluminium Alloy (silver or black)
Junction Box	IP67/IP68, 3 diodes
Output Cables	4mm ² , Length 300mm
Connector type	MC4 compatible

PACKING CONFIGURATIONS

Per Pallet	30 Pcs
Per 20' GP Container	360 Pcs
Per 40' HQ Container	858 Pcs

MAXIMUM RATINGS

Maximum system voltage (IEC)	1000V/1500V DC
Wind/Snow	5400Pa/2400Pa
Operating Temperature	-40 C ~ +85 C
Maximum series fuse rating	20A

Product And Quality Certifications

ISO 9001:2008 ISO 14001:2004 OHSAS 18001:2007



ENGINEERING DRAWINGS

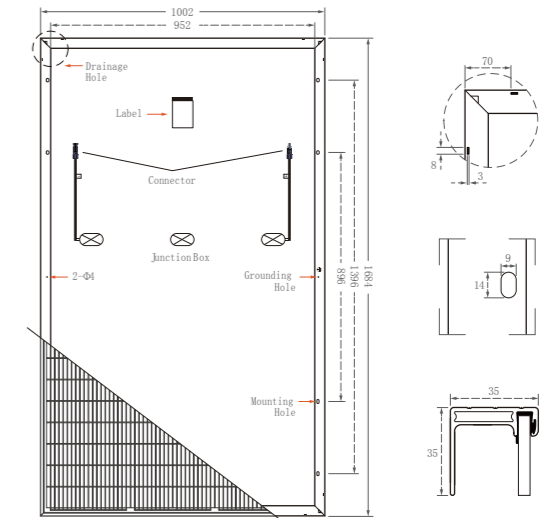

CURVE & TEMPERATURE DEPENDENCE

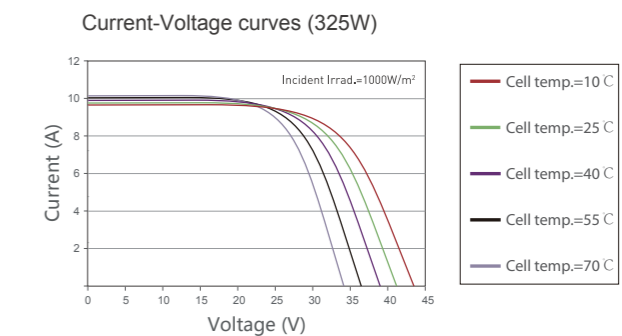
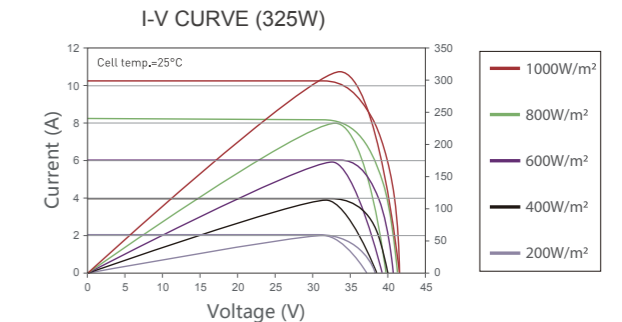

Excellent Manufacturing, Ultimate Pinergy.

9BB

Half-Cell MBB MONO MODULE

LIV-144M
395-420 Watt

Linear Performance Warranty

12 Years Product Warranty · 25 Years Linear Power Warranty

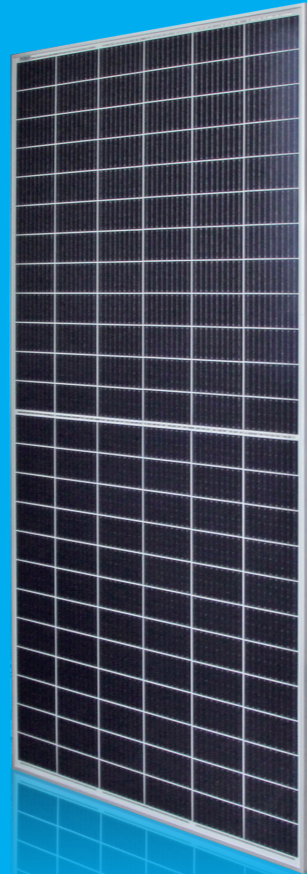
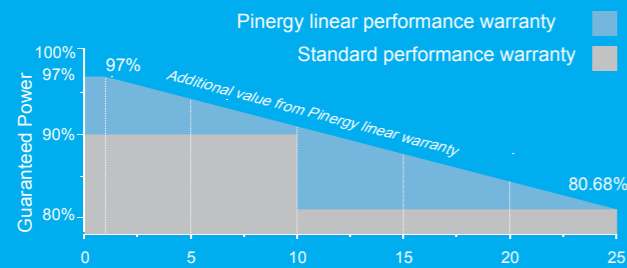

KEY FEATURES



Multi Busbar Solar Cell

Stronger current collection ability, Special circuit design with much lower hot spot temperature;



Module efficiency up to 20.45%

Half cell structure brings low resistance characteristic, higher lifetime generating capacity, simultaneously lower annual power attenuation;



PID Resistant

Excellent PID resistance at 96 hours (85°C/85%) test, and also can be improved to meet higher standards for the particularly harsh environment;



Low-Light Performance

Excellent power generation performance under Low-Light condition due to multi busbar; better shading response benefit from half cell module;



Anti-Crack

Excellent anti-microcracking performance with more balanced interior stress;



Strength and Durability

Certified for 5400Pa snow and 2400Pa loads test;

ELECTRICAL SPECIFICATIONS

Module Type	LIV144M-395		LIV144M-400		LIV144M-405		LIV144M-410		LIV144M-415		LIV144M-420	
	STC	NOCT	STC	NOCT	STC	NOCT	STC	NOCT	STC	NOCT	STC	NOCT
Testing Condition	STC	NOCT	STC	NOCT	STC	NOCT	STC	NOCT	STC	NOCT	STC	NOCT
Rated output (Pmp/Wp)	395	295.13	400	298.24	405	301.37	410	308.2	415	313	420	319.3
Rated voltage (Vmp/V)	40.27	37.5	40.61	37.8	40.96	38.1	41.0	38.4	41.30	38.6	41.59	38.9
Rated current (Imp/A)	9.81	7.87	9.85	7.89	9.89	7.91	10.00	8.03	10.05	8.13	10.10	8.21
Open circuit voltage (Voc/V)	48.63	45.3	48.93	45.6	49.23	45.8	50.2	46.8	50.38	47.7	51.28	48.3
Short circuit current (Isc/A)	10.33	8.35	10.36	8.38	10.39	8.40	10.47	8.48	10.55	8.60	10.63	9.20
Module efficiency(%)	19.63%		19.88%		20.13%		20.38%		20.63%		20.87%	
Power Tolerance (W)	0~+5		0~+5		0~+5		0~+5		0~+5		0~+5	

Standard Test Condition (STC) : Irradiance 1000W/m², Cell Temperature 25°C, AM1.5

Nominal Module Operating Temperature (NMOT): Irradiance 800W/m², Ambient Temperature 20°C, AM1.5, Wind Speed 1m/s

TEMPERATURE CHARACTERISTICS

NOCT Temperature	44°C ±2°C
Temperature Coefficient (Pmax)	-0.38%/°C
Temperature Coefficient (Voc)	-0.30%/°C
Temperature Coefficient (Isc)	0.06%/°C

MECHANICAL SPECIFICATIONS

Cell Type	9BB MONO 158.75×79.375mm
No. of Cells	144 (6×24)
Dimension	2008×1002×35mm
Weight	23.5kg
Glass	3.2mm, Low Iron Tempered Glass
Frame	Anodized Aluminium Alloy (silver or black)
Junction Box	IP67/IP68, 3 diodes
Output Cables	4mm ² , Length 300mm
Connector type	MC4 compatible

PACKING CONFIGURATIONS

Per Pallet	30 Pcs
Per 20' GP Container	300 Pcs
Per 40' HQ Container	704 Pcs

MAXIMUM RATINGS

Maximum system voltage (IEC)	1000V/1500V DC
Wind/Snow	5400Pa/2400Pa
Operating Temperature	-40°C ~ +85°C
Maximum series fuse rating	20A

Product And Quality Certifications

ISO 9001:2008 ISO 14001:2004 OHSAS 18001:2007



ENGINEERING DRAWINGS

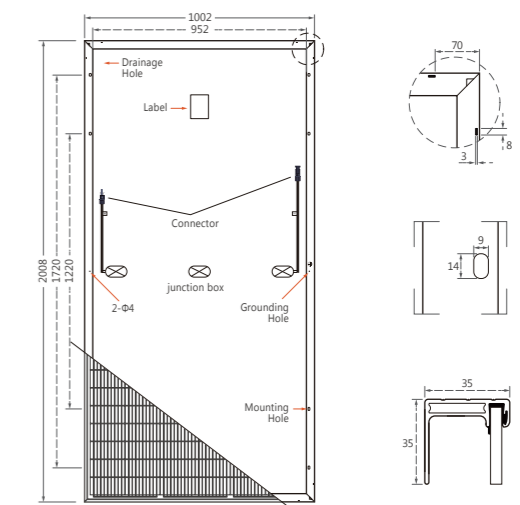

CURVE & TEMPERATURE DEPENDENCE

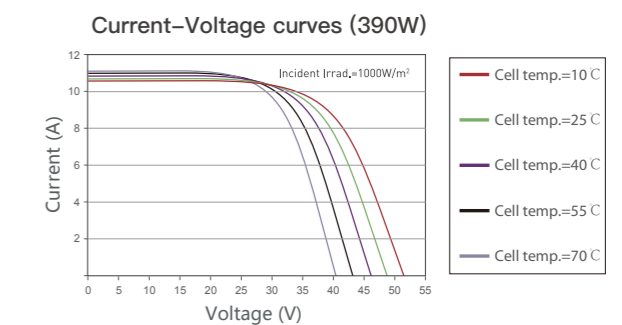
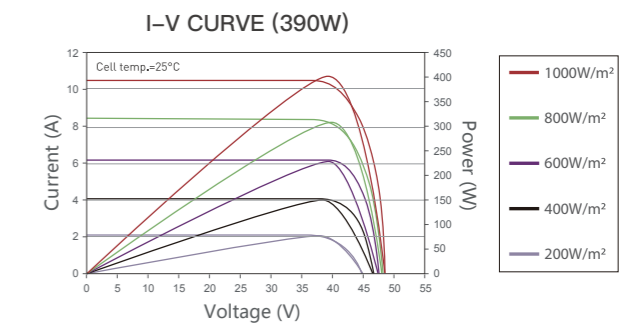

Excellent Manufacturing, Ultimate Pinergy.

9BB

Half-Cell MBB MONO MODULE

LIV-120M(166)

355-375 Watt

Linear Performance Warranty

12 Years Product Warranty · 25 Years Linear Power Warranty

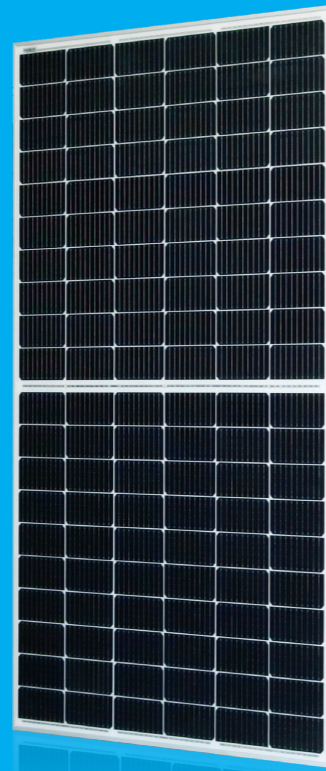
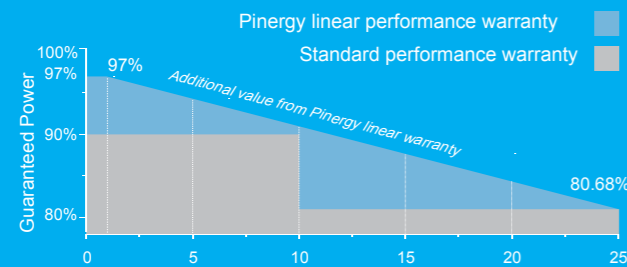

KEY FEATURES

Multi Busbar Solar Cell
Stronger current collection ability, Special circuit design with much lower hot spot temperature;

Module efficiency up to 20.27%
Half cell structure brings low resistance characteristic, higher lifetime generating capacity, simultaneously lower annual power attenuation;

Anti PID
Excellent PID resistance at 96 hours (85°C/85%) test, and also can be improved to meet higher standards for the particularly harsh environment;

Low-Light Performance
Excellent power generation performance under Low-Light condition due to multi busbar; better shading response benefit from half cell module;

Anti-Crack
Excellent anti-microcracking performance with more balanced interior stress;

Strength and Durability
Certified for 5400Pa snow and 2400Pa loads test;

ELECTRICAL SPECIFICATIONS

Module Type	LIV120M-355		LIV120M-360		LIV120M-365		LIV120M-370		LIV120M-375	
	STC	NOCT	STC	NOCT	STC	NOCT	STC	NOCT	STC	NOCT
Rated output (Pmp/Wp)	355	265	360	268	365	272	370	276	375	279
Rated voltage (Vmp/V)	33.5	31.0	33.7	31.1	33.9	31.3	34.1	31.5	34.3	31.7
Rated current (Imp/A)	10.60	8.56	10.68	8.62	10.77	8.69	10.85	8.76	10.93	8.80
Open circuit voltage (Voc/V)	40.7	38.2	40.9	38.4	41.1	38.6	41.3	38.7	41.5	38.9
Short circuit current (Isc/A)	11.30	9.12	11.40	9.20	11.50	9.28	11.60	9.36	11.70	9.44
Module efficiency(%)	19.19%		19.46%		19.56%		20.00%		20.27%	
Power Tolerance (W)	0~+5		0~+5		0~+5		0~+5		0~+5	

Standard Test Condition (STC) : Irradiance 1000W/m², Cell Temperature 25°C, AM1.5

Nominal Module Operating Temperature (NMOT): Irradiance 800W/m², Ambient Temperature 20°C, AM1.5, Wind Speed 1m/s

TEMPERATURE CHARACTERISTICS

NOCT Temperature	44°C ±2°C
Temperature Coefficient (Pmax)	-0.38%/°C
Temperature Coefficient (Voc)	-0.30%/°C
Temperature Coefficient (Isc)	0.06%/°C

MECHANICAL SPECIFICATIONS

Cell Type	9BB MONO 166×83mm
No. of Cells	120 (6×20)
Dimension	1765×1048×35mm
Weight	19.8kg
Glass	3.2mm, Low Iron Tempered Glass
Frame	Anodized Aluminium Alloy (silver or black)
Junction Box	IP67/IP68, 3 diodes
Output Cables	4mm ² , Length 300mm
Connector type	MC4 compatible

PACKING CONFIGURATIONS

Per Pallet	30 Pcs
Pallet/Container	26
Per 40' HQ Container	780 Pcs

MAXIMUM RATINGS

Maximum system voltage (IEC)	1500V DC
Wind/Snow	5400Pa/2400Pa
Operating Temperature	-40°C ~ +85°C
Maximum series fuse rating	20A

Product And Quality Certifications

ISO 9001:2008 ISO 14001:2004 OHSAS 18001:2007



ENGINEERING DRAWINGS

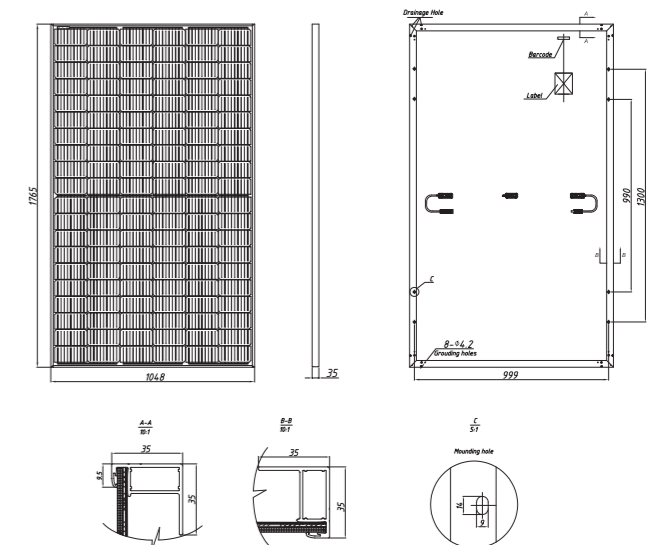

CURVE & TEMPERATURE DEPENDENCE

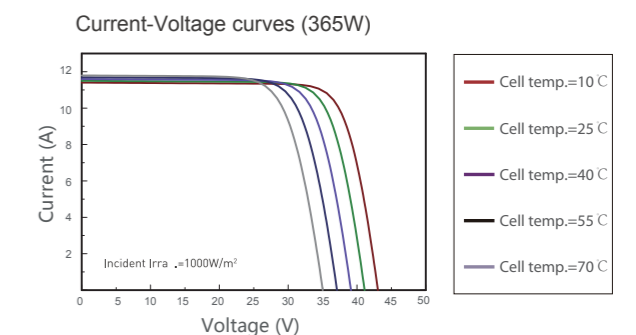
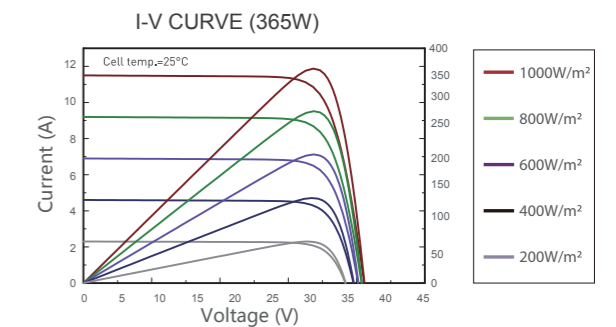

Excellent Manufacturing, Ultimate Pinergy.

9BB

Half-Cell MBB MONO MODULE

LIV-144M(166)

430-450 Watt

Linear Performance Warranty

12 Years Product Warranty · 25 Years Linear Power Warranty

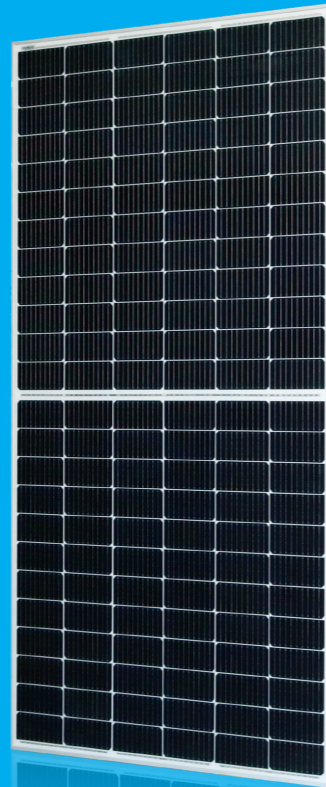
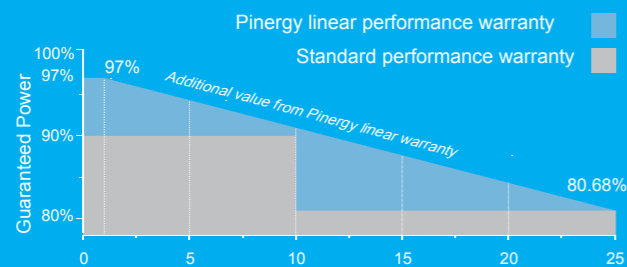

KEY FEATURES

Multi Busbar Solar Cell
Stronger current collection ability, Special circuit design with much lower hot spot temperature;

Module efficiency up to 20.37%
Half cell structure brings low resistance characteristic, higher lifetime generating capacity, simultaneously lower annual power attenuation;

Anti PID
PID Resistant
Excellent PID resistance at 96 hours (85 C /85%) test, and also can be improved to meet higher standards for the particularly harsh environment;

Low-Light Performance
Excellent power generation performance under Low-Light condition due to multi busbar; better shading response benefit from half cell module;

Anti-Crack
Excellent anti-microcracking performance with more balanced interior stress;

Strength and Durability
Certified for 5400Pa snow and 2400Pa loads test;

ELECTRICAL SPECIFICATIONS

Module Type	LIV144M-430		LIV144M-435		LIV144M-440		LIV144M-445		LIV144M-450	
	STC	NOCT	STC	NOCT	STC	NOCT	STC	NOCT	STC	NOCT
Rated output (Pmp/Wp)	430	318	435	322	440	325	445	329	450	333
Rated voltage (Vmp/V)	40.0	36.6	40.3	36.9	40.5	37.1	40.8	37.3	41.0	37.5
Rated current (Imp/A)	10.74	8.68	10.80	8.73	10.86	8.77	10.92	8.82	10.98	8.87
Open circuit voltage (Voc/V)	48.4	45.32	48.7	45.4	49.0	45.6	49.2	45.8	49.5	45.9
Short circuit current (Isc/A)	11.18	9.03	11.24	9.08	11.30	9.13	11.36	9.18	11.42	9.23
Module efficiency(%)	19.46%		19.63%		19.92%		20.14%		20.37%	
Power Tolerance (W)	0~+5		0~+5		0~+5		0~+5		0~+5	

Standard Test Condition (STC) : Irradiance 1000W/m², Cell Temperature 25 C, AM1.5

Nominal Module Operating Temperature (NMOT): Irradiance 800W/m², Ambient Temperature 20 C, AM1.5, Wind Speed 1m/s

TEMPERATURE CHARACTERISTICS

NOCT Temperature	44 C ±2 C
Temperature Coefficient (Pmax)	-0.38%/C
Temperature Coefficient (Voc)	-0.30%/C
Temperature Coefficient (Isc)	0.06%/C

MECHANICAL SPECIFICATIONS

Cell Type	9BB MONO 166×83mm
No. of Cells	144 (6×24)
Dimension	2108×1048×35mm
Weight	24.5kg
Glass	3.2mm, Low Iron Tempered Glass
Frame	Anodized Aluminium Alloy (silver or black)
Junction Box	IP67/IP68, 3 diodes
Output Cables	4mm ² , Length 300mm
Connector type	MC4 compatible

PACKING CONFIGURATIONS

Per Pallet	30 Pcs
Pallet/Container	22
Per 40' HQ Container	660 Pcs

MAXIMUM RATINGS

Maximum system voltage (IEC)	1500V DC
Wind/Snow	5400Pa/2400Pa
Operating Temperature	-40 C ~ +85 C
Maximum series fuse rating	20A

Product And Quality Certifications

ISO 9001:2008 ISO 14001:2004 OHSAS 18001:2007



ENGINEERING DRAWINGS

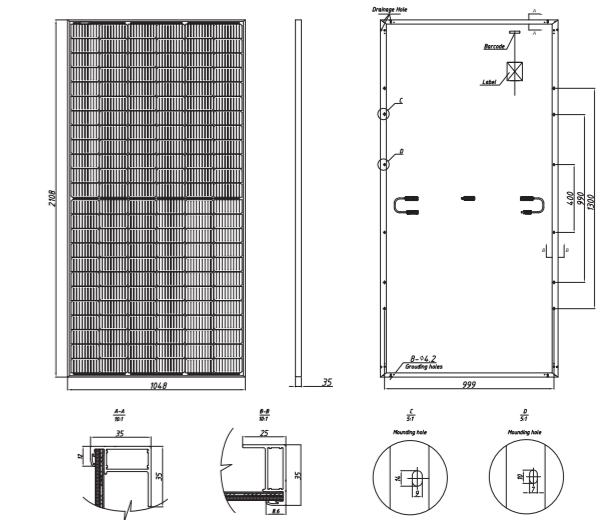

CURVE & TEMPERATURE DEPENDENCE

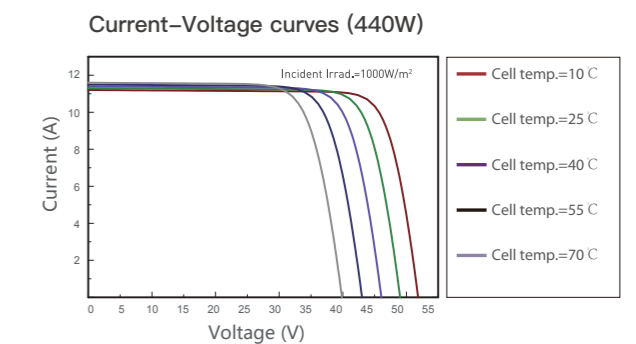
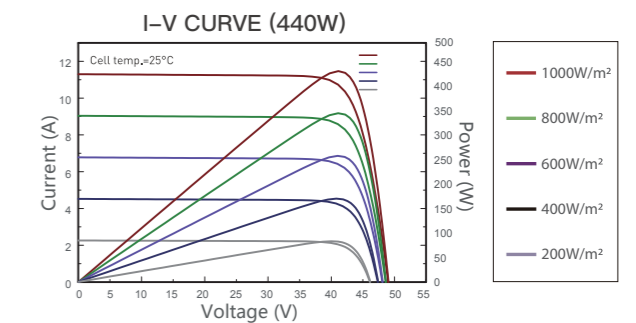

Excellent Manufacturing, Ultimate Livefun.

9BB

MONO CRYSTALLINE MODULE

LIV-144M (182MM)

525-550 Watt

Linear Performance Warranty

12 Years Product Warranty · 25 Years Linear Power Warranty

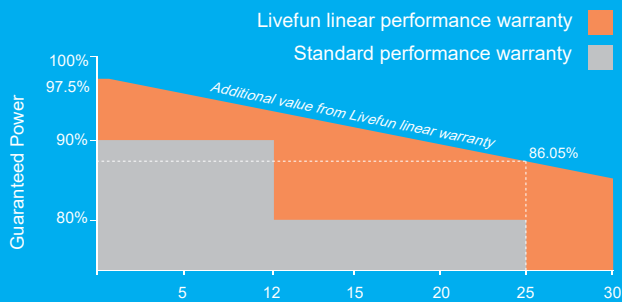

KEY FEATURES



IP68 junction box, connector

IP68 junction box and connector have a high degree of waterproof, effectively resist the harsh environment;



PID Resistant

Excellent PID resistance at 96 hours (85°C/85%) test, and also can be improved to meet higher standards for the particularly harsh environment;



9BB half-cut cell technology

New circuit design, lower internal current, lower Rs loss



Significantly lower the risk of hot spot

Special circuit design with much lower hot spot temperature



Lower LCOE

2% more power generation, lower LCOE

ELECTRICAL SPECIFICATIONS

Module Type	LIV 144M-525		LIV 144M-530		LIV 144M-535		LIV 144M-540		LIV 144M-545		LIV 144M-550	
	STC	NOCT	STC	NOCT	STC	NOCT	STC	NOCT	STC	NOCT	STC	NOCT
Testing Condition	STC	NOCT	STC	NOCT	STC	NOCT	STC	NOCT	STC	NOCT	STC	NOCT
Rated output (Pmp/Wp)	525	391.6	530	395.4	535	398.9	540	402.7	545	406.6	550	410.5
Maximum Power Voltage(Vmpp/V)	40.6	37.8	40.8	38.0	41.0	38.2	41.2	38.4	41.4	38.6	41.6	38.8
Maximum Power Current(Imp/A)	12.94	10.35	13.00	10.40	13.05	10.44	13.11	10.49	13.17	10.54	13.23	10.58
Open Circuit Voltage(Voc/V)	48.8	45.7	49.0	45.9	49.2	46.1	49.4	46.3	49.6	46.4	49.8	46.6
Short Circuit Current(Isc/A)	13.71	11.05	13.76	11.09	13.81	11.13	13.87	11.18	13.93	11.23	13.99	11.28
Module efficiency(%)	20.5%		20.7%		20.9%		21.1%		21.3%		21.5%	
Power Tolerance (W)	0~+5		0~+5		0~+5		0~+5		0~+5		0~+5	

Standard Test Condition (STC) : Irradiance 1000W/m², Cell Temperature 25 °C, AM1.5

Nominal Module Operating Temperature (NMOT): Irradiance 800W/m², Ambient Temperature 20 °C, AM1.5, Wind Speed 1m/s

TEMPERATURE CHARACTERISTICS

NOCT Temperature	43 °C ±2 °C
Temperature Coefficient (Pmax)	-0.36%/°C
Temperature Coefficient (Voc)	-0.26%/°C
Temperature Coefficient (Isc)	0.043%/°C

MECHANICAL SPECIFICATIONS

Cell Type	9BB MONO 182*182mm
No. of Cells	144 (6*24)
Dimension	2256*1133*35mm
Weight	29kg
Glass	3.2mm (0.13inches) , Tempered AR Glass
Frame	Anodized Aluminium Alloy (silver or black)
Junction Box	IP68, with Bypass Diodes
Output Cables	TUV, ±length 300mm, 4.0mm ²
Connector type	MC4 Compatible

PACKING CONFIGURATIONS

Container	40' HQ
Pieces Per Pallet	31
Pallets Per Container	20
Pieces Per Container	620

MAXIMUM RATINGS

Maximum System Voltage	1000V/1500V DC
Maximum Series Fuse	25A
Increased Snowload Acc.to Iec 61215	5400Pa
Operating Temperature	-40~+85°C
Number Of Bypass Diodes	3

Product And Quality Certifications

ISO 9001:2008 ISO 14001:2004 OHSAS 18001:2007



ENGINEERING DRAWINGS

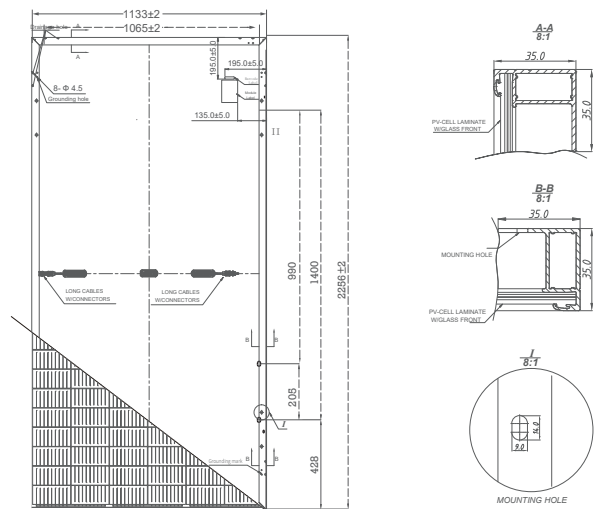

CURVE & TEMPERATURE DEPENDENCE

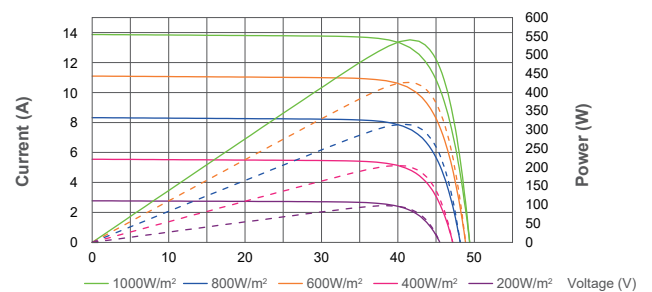

Power voltage current curve at different temperature

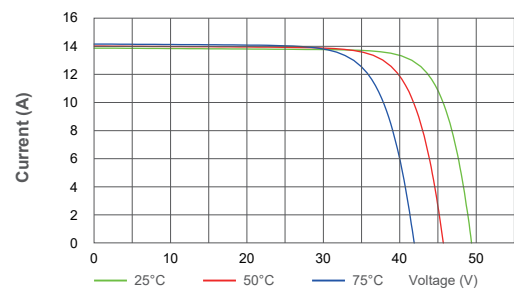

Excellent Manufacturing, Ultimate Livefun.

10BB

MONO CRYSTALLINE MODULE

LIV-156M (182MM)
570-590 Watt

Linear Performance Warranty

12 Years Product Warranty · 25 Years Linear Power Warranty

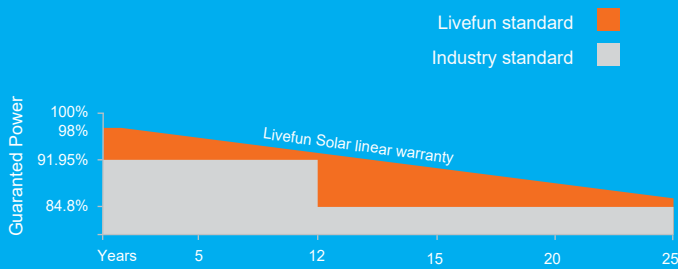

KEY FEATURES



IP68 junction box, connector

IP68 junction box and connector have a high degree of waterproof, effectively resist the harsh environment;



PID Resistant

Excellent PID resistance at 96 hours (85°C/85%) test, and also can be improved to meet higher standards for the particularly harsh environment;



10BB half-cut cell technology

New circuit design, lower internal current, lower Rs loss



Significantly lower the risk of hot spot

Special circuit design with much lower hot spot temperature



Lower LCOE

2% more power generation, lower LCOE

ELECTRICAL SPECIFICATIONS

Module Type	LIV 156M-570		LIV 156M-575		LIV 156M-580		LIV 156M-585		LIV 156M-590	
	STC	NOCT	STC	NOCT	STC	NOCT	STC	NOCT	STC	NOCT
Testing Condition	STC	NOCT	STC	NOCT	STC	NOCT	STC	NOCT	STC	NOCT
Rated output (Pmp/Wp)	570	420.2	575	423.7	580	427.6	585	431.1	590	434.6
Maximum Power Voltage(Vmpp/V)	44	41.1	44.2	41.3	44.4	41.4	44.6	41.6	44.8	41.8
Maximum Power Current(Imp/A)	12.96	10.22	13.01	10.27	13.07	10.32	13.12	10.36	13.17	10.41
Open Circuit Voltage(Voc/V)	52.9	49.4	53.1	49.6	53.3	49.8	53.5	50.0	53.7	50.2
Short Circuit Current(Isc/A)	13.69	11.04	13.75	11.08	13.81	11.13	13.87	11.18	13.94	11.23
Module efficiency(%)	20.3%		20.5%		20.7%		20.9%		21.0%	
Power Tolerance (W)	0~+5		0~+5		0~+5		0~+5		0~+5	

Standard Test Condition (STC) : Irradiance 1000W/m², Cell Temperature 25°C, AM1.5

Nominal Module Operating Temperature (NMOT): Irradiance 800W/m², Ambient Temperature 20°C, AM1.5, Wind Speed 1m/s

TEMPERATURE CHARACTERISTICS

NOCT Temperature	43°C ±2°C
Temperature Coefficient (Pmax)	-0.36%/°C
Temperature Coefficient (Voc)	-0.26%/°C
Temperature Coefficient (Isc)	0.043%/°C

MECHANICAL SPECIFICATIONS

Cell Type	10BB MONO 182*182mm
No. of Cells	156 (6*26)
Dimension	2472*1135*35mm
Weight	31.5kg
Glass	3.2mm (0.13inches), Tempered AR Glass
Frame	Anodized Aluminium Alloy (silver or black)
Junction Box	IP68, with Bypass Diodes
Output Cables	TUV, length 300mm, 4.0mm ²
Connector type	MC4 Compatible

PACKING CONFIGURATIONS

Container	40' HQ
Pieces Per Pallet	31
Pallets Per Container	18
Pieces Per Container	558

MAXIMUM RATINGS

Maximum System Voltage	1000V/1500V DC
Maximum Series Fuse	25A
Increased Snowload Acc.to Iec 61215	5400Pa
Operating Temperature	-40~+85°C
Number Of Bypass Diodes	3

Product And Quality Certifications

ISO 9001:2008 ISO 14001:2004 OHSAS 18001:2007



ENGINEERING DRAWINGS

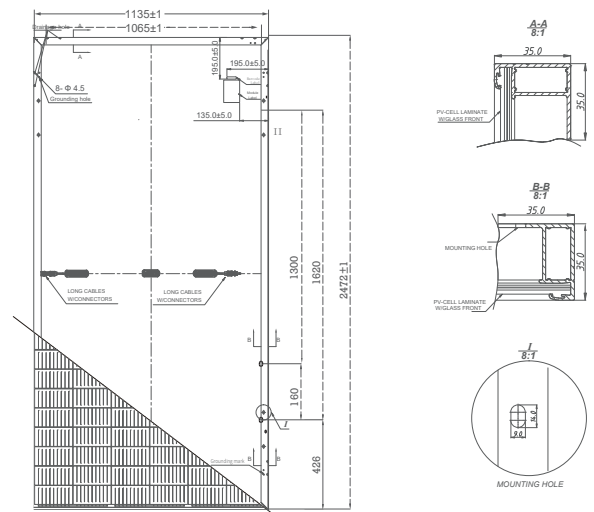

CURVE & TEMPERATURE DEPENDENCE

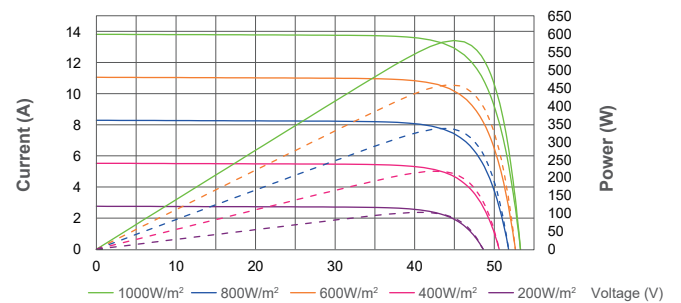

Power voltage current curve at different temperature

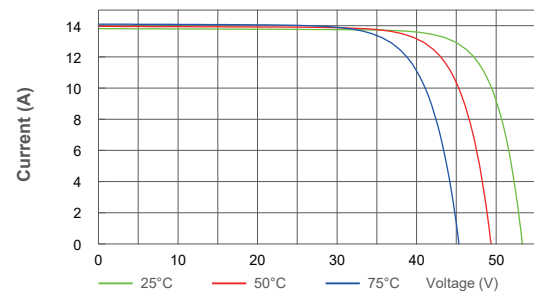

Excellent Manufacturing, Ultimate Livefun.

10BB

MONO CRYSTALLINE MODULE

LIV-150M (210MM)
485-505 Watt

Linear Performance Warranty

12 Years Product Warranty · 25 Years Linear Power Warranty

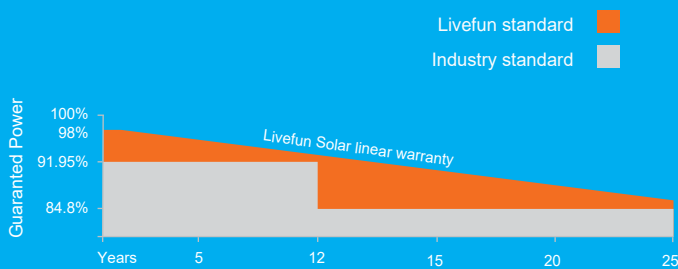

KEY FEATURES



IP68 junction box, connector

IP68 junction box and connector have a high degree of waterproof, effectively resist the harsh environment;



PID Resistant

Excellent PID resistance at 96 hours (85°C/85%) test, and also can be improved to meet higher standards for the particularly harsh environment;



10BB half-cut cell technology

New circuit design, lower internal current, lower Rs loss



Significantly lower the risk of hot spot

Special circuit design with much lower hot spot temperature



Lower LCOE

2% more power generation, lower LCOE

ELECTRICAL SPECIFICATIONS

Module Type	LIV 150M-485		LIV 150M-490		LIV 150M-495		LIV 150M-500		LIV 150M-505	
	STC	NOCT	STC	NOCT	STC	NOCT	STC	NOCT	STC	NOCT
Testing Condition	STC	NOCT	STC	NOCT	STC	NOCT	STC	NOCT	STC	NOCT
Rated output (Pmp/Wp)	485	357.7	490	361.2	495	365.1	500	368.7	505	372.2
Maximum Power Voltage(Vmpp/V)	42.3	39.6	42.5	39.7	42.7	39.9	42.9	40.1	43.1	40.2
Maximum Power Current(Imp/A)	11.47	9.04	11.53	9.09	11.60	9.15	11.66	9.20	11.72	9.25
Open Circuit Voltage(Voc/V)	51.0	47.6	51.2	47.8	51.4	48.0	51.6	48.2	51.8	48.3
Short Circuit Current(Isc/A)	12.10	9.76	12.17	9.82	12.24	9.88	12.31	9.93	12.38	9.99
Module efficiency(%)	19.9%		20.1%		20.3%		20.5%		20.7%	
Power Tolerance (W)	0~+5		0~+5		0~+5		0~+5		0~+5	

Standard Test Condition (STC) : Irradiance 1000W/m², Cell Temperature 25 °C, AM1.5

Nominal Module Operating Temperature (NMOT): Irradiance 800W/m², Ambient Temperature 20 °C, AM1.5, Wind Speed 1m/s

TEMPERATURE CHARACTERISTICS

NOCT Temperature	43 °C ±2 °C
Temperature Coefficient (Pmax)	-0.36%/°C
Temperature Coefficient (Voc)	-0.26%/°C
Temperature Coefficient (Isc)	0.043%/°C

MECHANICAL SPECIFICATIONS

Cell Type	10BB MONO 210*210mm
No. of Cells	150 (5*30)
Dimension	2214*1100*35mm
Weight	28kg
Glass	3.2mm (0.13inches) , Tempered AR Glass
Frame	Anodized Aluminium Alloy (silver or black)
Junction Box	IP68, with Bypass Diodes
Output Cables	TUV, length 300mm, 4.0mm ²
Connector type	MC4 Compatible

PACKING CONFIGURATIONS

Container	40' HQ
Pieces Per Pallet	31
Pallets Per Container	20
Pieces Per Container	620

MAXIMUM RATINGS

Maximum System Voltage	1000V/1500V DC
Maximum Series Fuse	20A
Increased Snowload Acc.to Iec 61215	5400Pa
Operating Temperature	-40~+85°C
Number Of Bypass Diodes	3

Product And Quality Certifications

ISO 9001:2008 ISO 14001:2004 OHSAS 18001:2007



ENGINEERING DRAWINGS

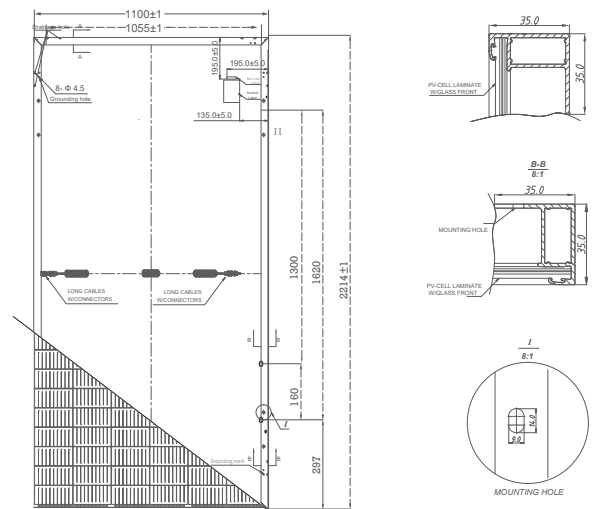

CURVE & TEMPERATURE DEPENDENCE

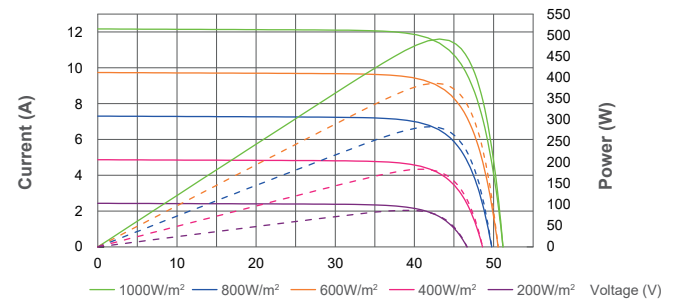

Power voltage current curve at different temperature

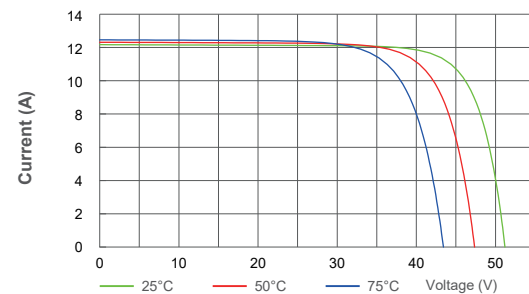

PROJECTS SOLAR POWER STATION

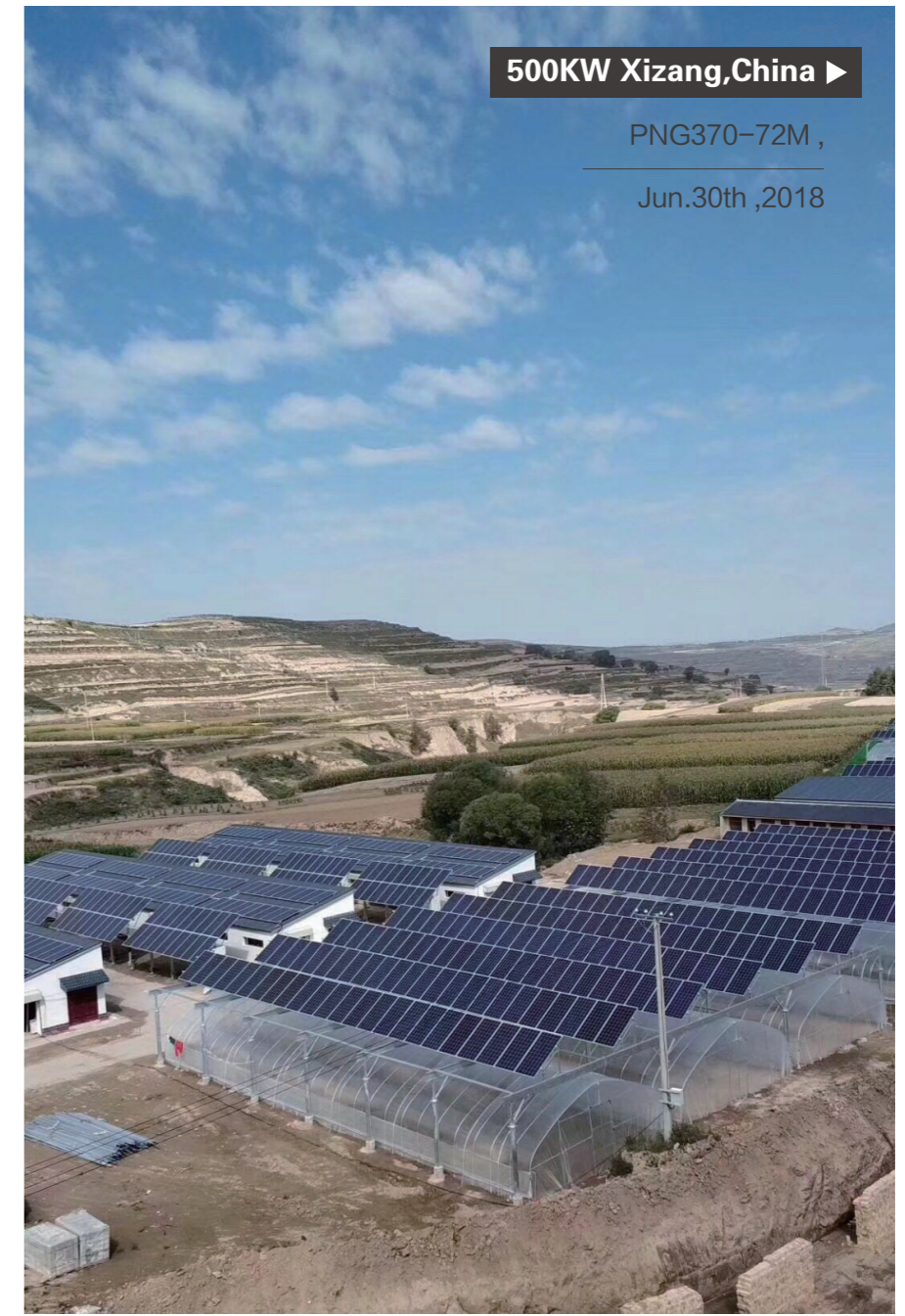

PROJECTS SOLAR POWER STATION



▲ 40kw in Veracruz, Mexico,
PNG275-60P,
Jun.7th ,2018



▲ 132KW ,Sana-Yemen ,
PNG370-72M,
Jul.7th,2018

PROJECTS SOLAR POWER STATION



◀ 15KW , PNG335-72P,
Pärnu,Estonia ,
Jun.15th ,2020



▲ 18KW ,Anhui China ,
PNG 260-60P ,
May 7th,2018



▼ 5KW ,Bac ninh ,Vietnam,
PNG375-72M,
Apr.6th,2019

